

# VRO Encoder Readout Quick Start Guide

(Refer to "VRO Reference Manual" for complete operation information)

## CAUTION:

**Readout and AC power supply should be operating in a well ventilated area. Do not use in a wet, dirty, or explosive environment. In industrial environments, repackaging into a NEMA grade enclosure is required.**

## Setup

1. Connect the Encoder cable(s) to the VRO
2. Connect cable from DC power adapter to VRO
3. Plug the DC power adapter into an AC outlet.

Model#: VRO-\_\_\_\_

Serial #: \_\_\_\_\_

If the box below is checked the VRO SET procedure is not required.

**VRO Factory Set to Settings Below**

Encoder E-1 (X)		Encoder E-2 (Y)	
<b>Enc Type:</b>		<b>Enc Type:</b>	
<input type="checkbox"/> Linear	<input type="checkbox"/> Rotary	<input type="checkbox"/> Linear	<input type="checkbox"/> Rotary
<b>Ln Res:</b>	<b>Cycles/Rev:</b>	<b>Ln Res:</b>	<b>Cycles/Rev:</b>
<input type="checkbox"/> 0.001 mm	<input type="checkbox"/> 100	<input type="checkbox"/> 0.001 mm	<input type="checkbox"/> 100
<input type="checkbox"/> 0.002 mm	<input type="checkbox"/> 200	<input type="checkbox"/> 0.002 mm	<input type="checkbox"/> 200
<input type="checkbox"/> 0.005 mm	<input type="checkbox"/> 400	<input type="checkbox"/> 0.005 mm	<input type="checkbox"/> 400
<input type="checkbox"/> 0.010 mm	<input type="checkbox"/> 500	<input type="checkbox"/> 0.010 mm	<input type="checkbox"/> 500
<b>Device:</b>		<b>Device:</b>	
<input type="checkbox"/> Ld Screw	<input type="checkbox"/> Rot Tbl	<input type="checkbox"/> Ld Screw	<input type="checkbox"/> Rot Tbl
<b>Adv/Rev:</b>	<b>Gear Ratio:</b>	<b>Adv/Rev:</b>	<b>Gear Ratio:</b>
<input type="checkbox"/> 0.025 in	<input type="checkbox"/> 90:1	<input type="checkbox"/> 0.025 in	<input type="checkbox"/> 90:1
<input type="checkbox"/> 1.0 mm	<input type="checkbox"/> 72:1	<input type="checkbox"/> 1.0 mm	<input type="checkbox"/> 72:1
<input type="checkbox"/> 0.05 in	<input type="checkbox"/> 36:1	<input type="checkbox"/> 0.05 in	<input type="checkbox"/> 36:1
<input type="checkbox"/> 2.0 mm	<input type="checkbox"/> 18:1	<input type="checkbox"/> 2.0 mm	<input type="checkbox"/> 18:1
<input type="checkbox"/> 0.10 in	<input type="checkbox"/> 1:1	<input type="checkbox"/> 0.10 in	<input type="checkbox"/> 1:1
<input type="checkbox"/> 0.20 in		<input type="checkbox"/> 0.20 in	
<input type="checkbox"/> 0.40 in		<input type="checkbox"/> 0.40 in	
<input type="checkbox"/> 100 mm		<input type="checkbox"/> 100 mm	
<b>Direction: Std</b>		<b>Direction: Std</b>	
<b>Disply Res: High</b>		<b>Disply Res: High</b>	
<b>Prim Units: Std</b>		<b>Prim Units: Std</b>	

**NOTE:** Scaling, number of decimal places, and units can be configured for virtually any encoder/device combination through the serial port. Go to [www.velmexcontrols.com](http://www.velmexcontrols.com) for more information.

## VRO SET

4. To enter VRO SET mode press both the "S" and "U" buttons for > 1 second when the following screen is displayed.



5. Press "S" button to set encoder E-1 when the following screen is displayed.

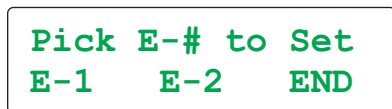

**NOTE:** VRO-1 models will not have "E-2" shown

6. Press "C" button to set/Change Encoder Type

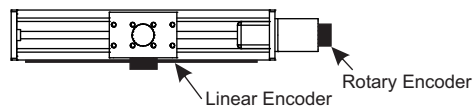
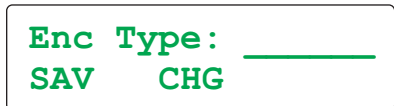

7. Press "S" button to Save setting and exit menu

8. For Rotary encoders skip to step 10

### Linear Encoders

9. Press "C" button to set/Change **Linear Resolution**<sup>†</sup> (usually 0.001 mm) Press "S" button to Save setting and exit menu. Go to step 14.

### Rotary Encoders

10. Press "C" button to Change **Cycles/Rev**<sup>‡</sup>, Press "S" button to Save/exit menu

11. Press "C" button to Change **Device**, Press "S" button to Save/exit menu. If device Rot Tbl (Rotary Table) go to step 13.

<sup>†</sup> **Linear Resolution** can be verified empirically by comparing display reading to distance carriage/slider moves measured with a ruler or caliper.

<sup>‡</sup> **Cycles/Rev** (CPR) can be determined empirically by temporarily setting CPR to "\_\_\_\_" and rotating the encoder exactly 1 revolution. The display will show raw counts (ct) from the encoder. Dividing this value by 4 equals the CPR.

## Front (Scale: 1/2)

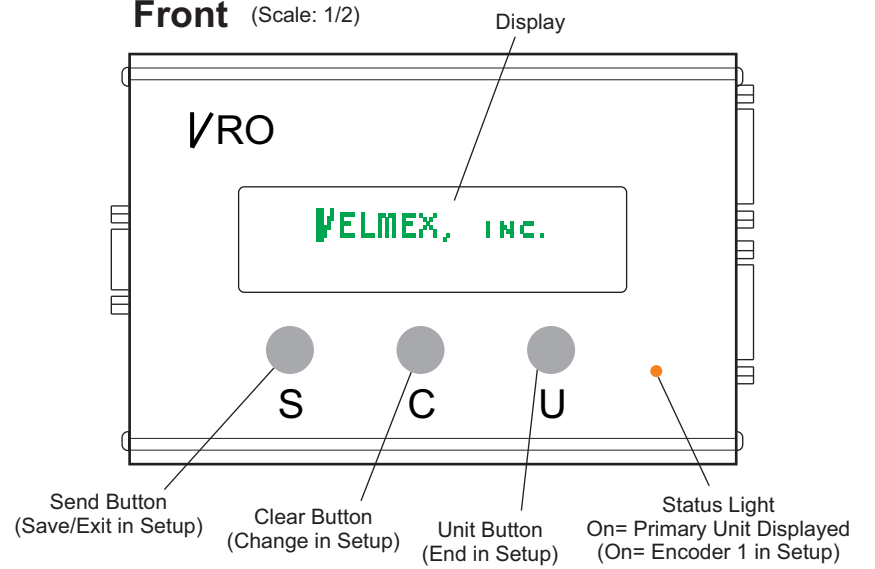

## Left

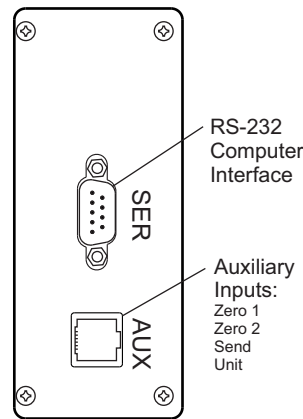

## Right

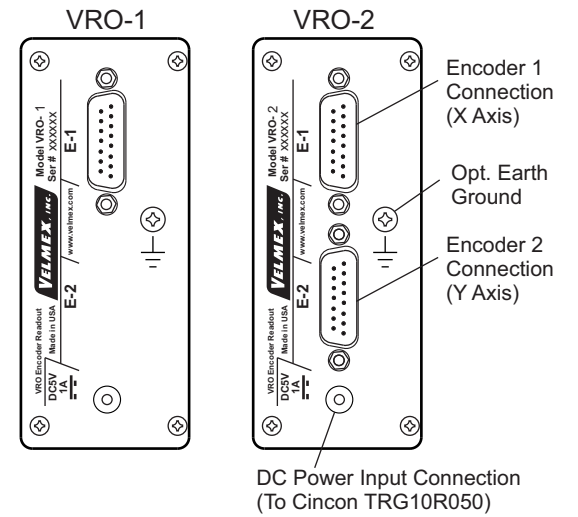

## Top VRO-1B/2B

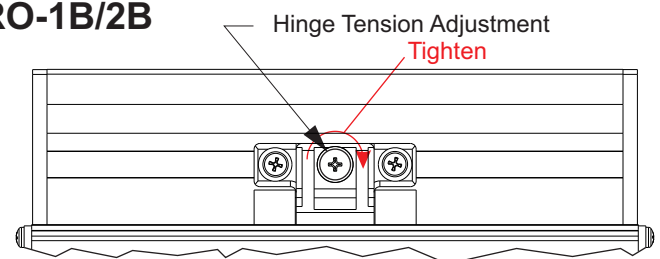

### Rotary Encoder & Lead Screw

12. Press "C" button to Change **Adv/Rev**, Press "S" button to Save/exit menu. Refer to the table below to determine Advance per Rev from slide model number. Go to step 14.

	UniSlide*	BiSlide**	Adv/Rev
		XSlide***	
C	P40	E25	0.025 in
K1	Q1	M01	1.0 mm
B	P20	E50	0.05 in
K2	Q2	M02	2.0 mm
W1	P10	E01	0.10 in
W2	P5	E02	0.20 in
W4	P2.5	E04	0.40 in

\* Typical UniSlide model (where x is from above table): MA4009x-S4

\*\* Typical BiSlide model (where x is from above table): MN10-0100-x-21

\*\*\* Typical XSlide model (where x is from above table): XN10-0040-x-71

### Rotary Encoder & Rotary Table

13. Press "C" button to Change **Gear Ratio**, Press "S" button to Save/exit menu. Refer to the table below to determine Gear Ratio from rotary table model number.

Model #	Gear Ratio
B5990	90:1
B4872	72:1
B4836	36:1
B4818	18:1

### Direction: Std

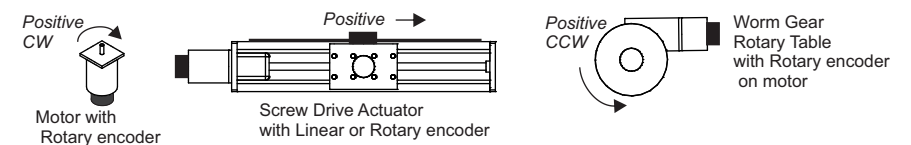

14. Press "C" button to Change **Direction**, Press "S" button to Save/exit menu

15. Press "C" button to Change **Display Resolution**, Press "S" button to Save/exit menu

16. Press "C" button to Invert **Primary/Secondary Unit**, Press "S" button to Save/exit menu

17. Press "U" button to **End** Encoder Setup

18. If used with a computer Press "C" button to change serial port baud rate

VRO Version X.XX  
EMU SER END

19. Press "U" button to **End/Update** Setup

## Operation

# VRO Encoder Readout

## Operation

1. For Display mode press the "C" button when the following screen is displayed.



### Power-up Options

- A. To skip Splash screen hold "S" button down when power is applied
- B. To skip both Splash & Start screens hold "C" button down when power is applied
- C. To do a pixel illumination test hold "U" button down when power is applied

### Display Mode

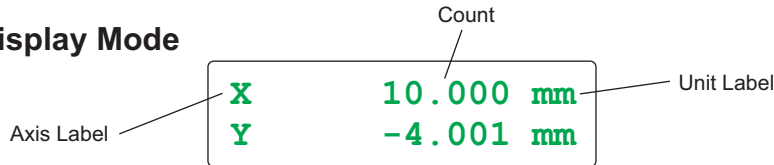

### Clearing Count (VRO-1)

2. Press the "C" button to zero the encoder count



### Clearing Count (VRO-2)

- 2A. Press the "C" button, the second line of the display will show the zero submenu:



- 2B. Press the "S" button to zero X axis, press the "C" button to zero Y axis, the "U" button to zero X & Y axes,

### Primary/Secondary Units

3. Press and release the "U" button to toggle between units.  
NOTE: The status light is on for primary and off for secondary units.

#### Standard Units

mm	Millimeters
in	Inches
o	Decimal Degrees
rv	Revolutions
ct	Raw Encoder Counts (default when VRO Setup not completed)

### Send Count to Host Computer

4. Press the "S" button to Send the display count out the Serial port.  
The status light will flash for duration of the send.  
For more information on the Send format refer to the "setO" command in the "VRO Reference Manual" at [www.velmexcontrols.com](http://www.velmexcontrols.com)  
There is user resettable Send Counter that counts the number of Sends.



Counter Value

### Viewing & Clearing Send Counter

5. Hold the "U" button down and press the "S" button to display the Send Counter menu:

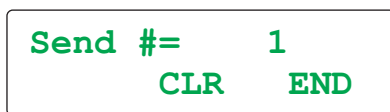

6. Press the "C" button to Clear the Send Counter, press "U" to End menu

### Sleep Mode

7. To put the VRO into Sleep mode hold the "U" button down >2 seconds until "( Sleep mode" is displayed.  
The display will blank and the status light will flash on/off continuously at a 1 second rate.  
To exit sleep press "U" button, or send any character in the Serial port.

**NOTE:** The VRO fully powers attached encoders and keeps counting while in sleep mode.

### Troubleshooting

- ◆ Status light flashing rapidly and display shows partial information or odd characters
- ✘ Power is intermittent /was interrupted, check power input connector & cycle power
- ◆ Status light pulsating and display shows ">5 INPUT VOLTS !"
- ✘ Power in is greater than 5.4 volts, disconnect power adapter and check it's voltage
- ◆ Status light pulsating and display shows "<5 INPUT VOLTS !"
- ✘ Power in is less than 4.6 volts, check power adapter voltage, and encoder load
- ◆ Status light pulsating and display shows "Enc Input Fail !"
- ✘ Poor encoder connection, electrical interference, or count exceeding 1.6 MHz

## VRO On-Line/ Setup Mode Commands\*

<b>Q</b>	Quit On-Line mode (return to Display mode)
<b>quit</b>	Quit On-Line mode without backing-up changes
<b>res</b>	Reset VRO (returns to Power-up display)
<b>fpsetup</b>	Display Front Panel setup menu
<b>lock</b>	Disable Front Panel setup mode at power-up
<b>unlock</b>	Enable Front Panel setup mode at power-up (default)
<b>I1v</b>	Preset encoder 1 (raw) count to value "v", v= 0 to +/- 2147483647
<b>I2v</b>	Preset encoder 2 (raw) count to value "v", v= 0 to +/- 2147483647
<b>PT[[</b>	Start Pass-Through mode
<b>]</b>	Close Pass-Through mode and maintain current screen
<b>]]</b>	Close Pass-Through mode and restore "On-Line" screen
<b>Status request commands:</b>	
<b>V</b>	Verify Readout's status, VRO sends "S" to host to indicate in Setup mode
<b>~</b>	Read state of buttons/inputs
<b>@</b>	Read analog converted value of input voltage (755 to 805)
<b>getD0</b>	Read firmware version
<b>getD1</b>	Read date code
<b>getD2</b>	Read number of axes (1= 1 encoder, 2=2 encoder)
<b>getD3</b>	Read model number
<b>getO</b>	Read Output format used by Send ("S" button and "S" command)
<b>getQ</b>	Read Quadrature direction setting (0= both std, 1= 1 inv, 2= 2 inv, 3= both inv)
<b>getAX</b>	Read Axis label for encoder 1
<b>getAY</b>	Read Axis label for encoder 2
<b>getUX</b>	Read primary Unit label for encoder 1
<b>getUx</b>	Read secondary Unit label for encoder 1
<b>getUY</b>	Read primary Unit label for encoder 2
<b>getUy</b>	Read secondary Unit label for encoder 2
<b>getPx</b>	Read primary decimal Place for encoder 1
<b>getPxx</b>	Read secondary decimal Place for encoder 1
<b>getPY</b>	Read primary decimal Place for encoder 2
<b>getPy</b>	Read secondary decimal Place for encoder 2
<b>get*X</b>	Read primary Multiplier for encoder 1
<b>get*x</b>	Read secondary Multiplier for encoder 1
<b>get*Y</b>	Read primary Multiplier for encoder 2
<b>get*y</b>	Read secondary Multiplier for encoder 2
<b>get/X</b>	Read primary Divisor for encoder 1
<b>get/x</b>	Read secondary Divisor for encoder 1
<b>get/Y</b>	Read primary Divisor for encoder 2
<b>get/y</b>	Read secondary Divisor for encoder 2

#### Set commands:

<b>setD0</b>	Set VRO to default settings (all settings get cleared)
<b>setD1</b>	Set Front Panel setup to defaults
<b>setD2</b>	Set Scaling, Decimal Place, and Units to defaults
<b>setD3</b>	Set Output format to defaults
<b>setOv</b>	Set Output format used by Send, v= 1,2,X,x,Y,y,U,C,L,<space> (max 100 char)
<b>setQv</b>	Set Quadrature counting direction (v= 0= both std, 1= 1 inv, 2= 2 inv, 3= both inv)
<b>setAXv</b>	Set Axis label for encoder 1, v= any ASCII character
<b>setAYv</b>	Set Axis label for encoder 2, v= any ASCII character
<b>setUXv</b>	Set primary Unit label for encoder 1, v= any 2 ASCII characters
<b>setUxv</b>	Set secondary Unit label for encoder 1, v= any 2 ASCII characters
<b>setUYv</b>	Set primary Unit label for encoder 2, v= any 2 ASCII characters
<b>setUyv</b>	Set secondary Unit label for encoder 2, v= any 2 ASCII characters
<b>setPxv</b>	Set primary decimal Place for encoder 1, v= 0 to 8
<b>setPxxv</b>	Set secondary decimal Place for encoder 1, v= 0 to 8
<b>setPYv</b>	Set primary decimal Place for encoder 2, v= 0 to 8
<b>setPyv</b>	Set secondary decimal Place for encoder 2, v=0 to 8
<b>set*Xv</b>	Set primary Multiplier for encoder 1, v= 1 to 200000
<b>set*xv</b>	Set secondary Multiplier for encoder 1, v= 1 to 200000
<b>set*Yv</b>	Set primary Multiplier for encoder 2, v= 1 to 200000
<b>set*yv</b>	Set secondary Multiplier for encoder 2, v= 1 to 200000
<b>set/Xv</b>	Set primary Divisor for encoder 1, v= 1 to 200000
<b>set/xv</b>	Set secondary Divisor for encoder 1, v= 1 to 200000
<b>set/Yv</b>	Set primary Divisor for encoder 2, v= 1 to 200000
<b>set/yv</b>	Set secondary Divisor for encoder 2, v= 1 to 200000

## VRO Display Mode Commands\*

<b>E</b>	Enable On-Line/Setup mode with echo "on"
<b>F</b>	Enable On-Line/Setup mode with echo "off"
<b>C or N</b>	Clear/Null (zero) encoder position registers
<b>&lt;</b>	Clear (zero) encoder 1 position register
<b>&gt;</b>	Clear (zero) encoder 2 position register
<b>U</b>	Display Primary Unit
<b>u</b>	Display Secondary Unit
<b>B</b>	Blank display (Sleep mode)

#### Status request commands:

<b>V</b>	Verify Readout's status, VRO sends "D" to host to indicate in Display mode
<b>1</b>	Send raw count encoder 1 to host
<b>2</b>	Send raw count encoder 2 to host
<b>X</b>	Send displayed encoder 1 primary position to host
<b>x</b>	Send displayed encoder 1 secondary position to host
<b>Y</b>	Send displayed encoder 2 primary position to host
<b>y</b>	Send displayed encoder 2 secondary position to host
<b>S</b>	Send formatted display to host (same as "S" button) See "setO" command to configure format
<b>#</b>	Send count for # times "S" button pressed

\* Go to [www.velmexcontrols.com](http://www.velmexcontrols.com) for more information

## Contact Information

By Phone: 585-657-6151 and 800-642-6446  
By Fax: 585-657-6153  
Email: [velmexcontrols@velmex.com](mailto:velmexcontrols@velmex.com)  
On the Internet: [www.velmex.com](http://www.velmex.com) and [www.velmexcontrols.com](http://www.velmexcontrols.com)  
By mail: Velmex, Inc.  
7550 State Route 5 & 20  
Bloomfield, NY 14469 USA

Copyright 2013 Velmex Inc. All rights reserved. Velmex, the Velmex logo, UniSlide, and BiSlide are trademarks of Velmex Inc. All other trademarks are the property of their respective owners.

**VELMEX, INC.**