

VXM Stepping Motor Controller

Application Note # AN107

Interfacing to Solid State Relay Modules To Control External Devices

The VXM can only power logic level devices (5 VDC, 20 mA) directly from its user outputs. To control higher power devices optically isolated solid state relay modules need to be used. Optically isolated solid state relays should always be used when actuating devices like mechanical relays, solenoids, motors, lamps, and heaters. This application note describes the connection and control method to switch optically isolated solid state relays from the VXM's user outputs 1 and 2.

Materials Needed:

1. Relay Module Rack (Grayhill 70RCK4R)
2. DC relay module if load is DC (Grayhill 70-ODC5 for DC loads to 60VDC, 3.5 A)
AC relay module if load is AC (Grayhill 70-OAC5 for AC loads to 140VAC, 3.5 A)
3. Hook up wire
4. Auxiliary I/O Breakout Module or DB15HD (VGA) cable

Wiring VXM to Rack/Relays:

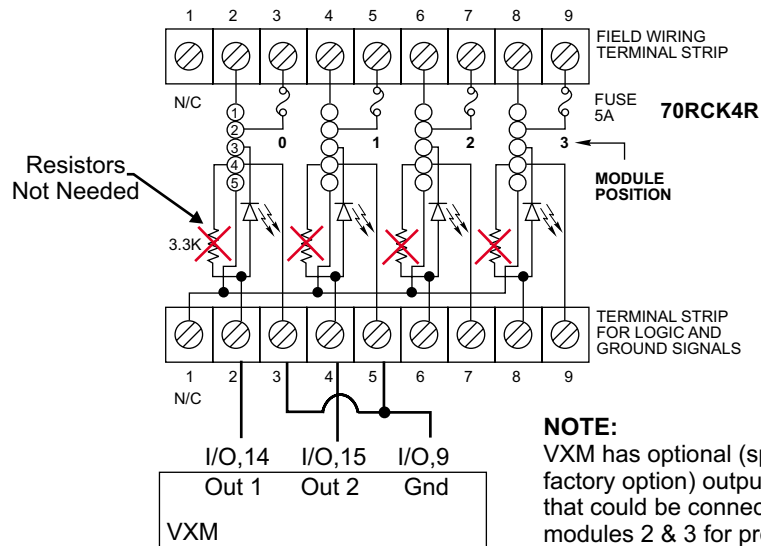

NOTE:
VXM has optional (special order factory option) outputs 3 & 4 that could be connected to modules 2 & 3 for providing a total of 4 relay outputs.

VXM Output 1 Controls Module 0
VXM Output 2 Controls Module 1

Wiring Relays to Load:

(Shown With Module 0 for DC, Module 1 for AC Load)

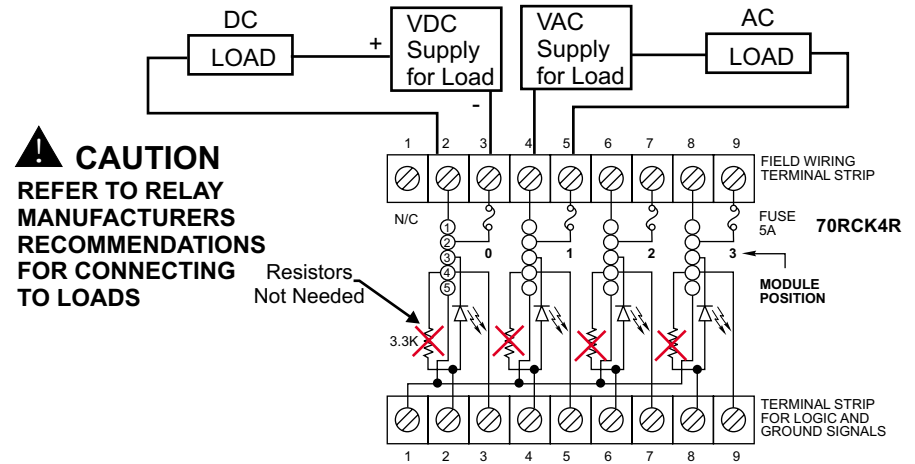

CAUTION
REFER TO RELAY
MANUFACTURERS
RECOMMENDATIONS
FOR CONNECTING
TO LOADS

Program:

| Example #1 | RAM used | Function |
|------------|----------|--------------------------------|
| Output 1 | 8 | Output 1 on only when Indexing |

```
U5          ;Output 1 on (high)
I1M4000    ;Index
U4          ;Output 1 off (low)
R
```

| Example #2 | RAM used | Function |
|------------|----------|----------------------------|
| Output 2 | 8 | Output 2 off when Indexing |

```
U14        ;Output 2 off (low)
I1M4000    ;Index
U15        ;Output 2 on (high)
R
```

7550 State Route 5 & 20
Bloomfield, NY 14469 USA
www.velmex.com

